



ZAVOD ZA
GRADBENIŠTVO
SLOVENIJE

SLOVENIAN
NATIONAL BUILDING
AND CIVIL ENGINEERING
INSTITUTE



član EOTA
Member of EOTA

Dimičeva 12
1000 Ljubljana, Slovenija

Tel.: +386 (0)1-280 44 72, 280 45 37

Fax: +386 (0)1-280 44 84

E-pošta: info.ta@zag.si

http://www.zag.si

European Technical Assessment

ETA-10/0093
of 20.02.2015

English version prepared by ZAG

I GENERAL PART

Komercialno ime

Trade name

FM-MP3[®] evo A4

Imetnik tehnične ocene

Holder of Technical Assessment

FRIULSIDER S.p.A.

via Trieste 1

33048 San Giovanni al Natisone (UD)

Italy

Družina proizvalca

Product family

**Kovinsko sidro izdelano iz nerjavečega jekla,
velikosti M6, M8, M10 in M12 za nekonstrukcijsko
skupinsko uporabo v betonu**

*Metal anchor made of stainless steel of sizes M6, M8, M10 and
M12 for multiple use in non-structural application in concrete*

Proizvodni obrat

Manufacturing plant

FRIULSIDER S.p.A.

via Trieste 1

33048 San Giovanni al Natisone (UD)

Italy

Ta Evropska tehnična ocena vsebuje

*This European Technical Assessment
contains*

8 strani vključno s 5 prilogami, ki so sestavni del te
ocene

*8 pages including 5 annexes, which form an integral part of the
document*

Ta Evropska tehnična ocena je
izdana na podlagi Uredbe (EU) št.
305/2011 na osnovi

*This European Technical Assessment is
issued in accordance to Regulation (EU)
No 305/2011, on the basis of*

Smernice za evropska tehnična soglasja ETAG 001 –
del 1 in 6, izdaja 2011, ki se uporablja kot EAD

*Guideline for European Technical Approval ETAG 001 – part 1
and 6, edition 2011, used as EAD*

Ta ocena zamenjuje

This Assessment replaces

ETA-10/0093 izdano dne 10.05.2010

ETA-10/0093 issued on 10.05.2010

Translations of this European Technical Assessment in other languages shall fully correspond to the original issued document and should be identified as such.

Communication of this European Technical Assessment, including transmission by electronic means, shall be in full (excepted the confidential Annex(es) referred to above). However, partial reproduction may be made, with the written consent of the issuing Technical Assessment Body. Any partial reproduction has to be identified as such.

II SPECIFIC PART OF THE EUROPEAN TECHNICAL ASSESSMENT

1 Technical description of the product

The FM-MP3[®] evo A4 in the range of M6, M8, M10 and M12 is an anchor made of stainless steel, which is placed into a drilled hole and anchored by torque-controlled expansion.

For the installed anchor see Figure given in Annex A1.

2 Specification and intended use

The performances given in Chapter 3 are only valid if the anchor is used in compliance with the specifications and conditions given in Annex B.

The provisions made in this European Technical Assessment are based on an assumed working life of the anchor of 50 years. The indications given on the working life cannot be interpreted as a guarantee given by the manufacturer, but are to be regarded only as a means for choosing the right products in relation to the expected economically reasonable working life of the works.

3 Performance of the product and references to the methods used for this assessment

3.1 Mechanical resistance and stability (BWR 1)

The basic work requirements for mechanical resistance and stability are listed in Annex C1.

3.2 Safety in case of fire (BWR 2)

The basic work requirements for safety in case of fire are listed in Annex C1.

3.3 Hygiene, health and environment (BWR 3)

Regarding dangerous substances contained in this European Technical Assessment, there may be requirements applicable to the products falling within its scope (e.g. transported European legislation and national laws, regulations and administrative provisions). In order to meet provisions of the regulation (EU) No 305/2011, these requirements need also to be complied with, when they apply.

3.4 Safety in use (BWR 4)

For basic work requirement safety in use the same criteria are valid as for basic work requirement mechanical resistance and stability.

3.5 Protection against noise (BWR 5)

Not relevant.

3.6 Energy economy and heat retention (BWR 6)

Not relevant.

3.7 Sustainable use of natural resources (BWR 7)

No performance determined.

3.8 General aspects relating to fitness for use

Durability and serviceability are only ensured if specifications of intended use according to Annex B1 are kept.

4 Assessment and verification of constancy of performance

According to the decision 97/161/EC of the European Commission¹ the system of assessment and verification of constancy of performance (see Annex V to regulation (EU) No 305/2011) given in the following table apply.

Product	Intended use	Level of class	System
Metal anchors for use in concrete (light-duty type)	For use in redundant systems for fixing and/or supporting to concrete elements such as lightweight suspended ceilings, as well as installations	-	2+

5 Technical details necessary for the implementation of the AVCP system

5.1 Tasks for the manufacturer

Technical details necessary for the implementation of the AVCP system are laid down in the Control plan deposited at the Slovenian National Building and Civil Engineering Institute (ZAG).

Issued in Ljubljana on 20.02.2015

Signed by:

Franc Capuder, M.Sc., Research Engineer

Head of Service of TAB

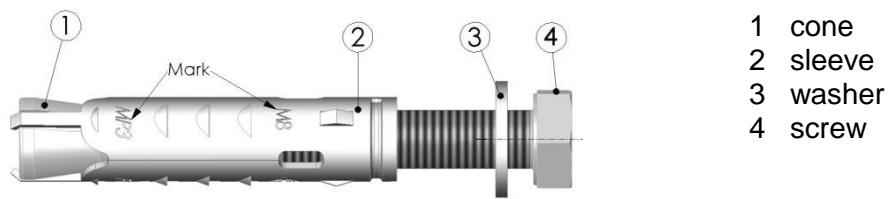

Figure A1: FM-MP3[®] evo A4 anchor

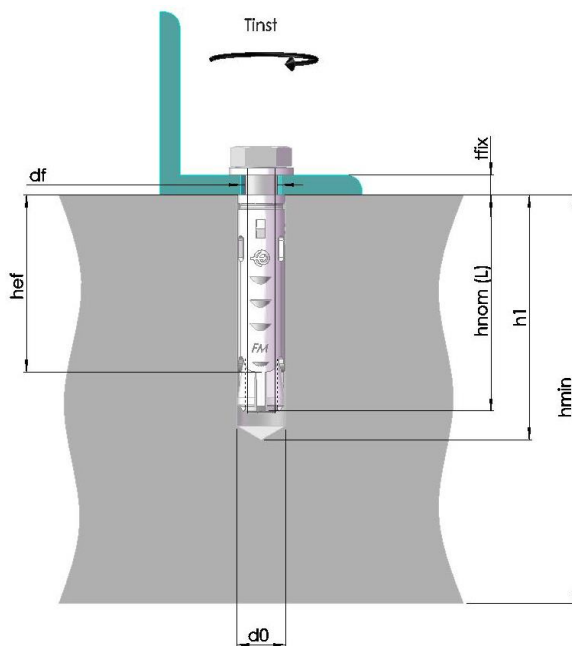

Figure A2: Installed FM-MP3[®] evo A4 anchor

FM-MP3[®] evo A4

Product description

Product and intended use

Annex A1

Table A1: Dimensions of different parts of an anchor

Anchor type	h_{nom} (mm)	L (mm)	d (mm)	d_0 (mm)	L_{screw} (mm)
FM-MP3 [®] evo A4 M6	45	45	6	10	(1)
FM-MP3 [®] evo A4 M8	50	50	8	12	(1)
FM-MP3 [®] evo A4 M10	60	60	10	15	(1)
FM-MP3 [®] evo A4 M12	80	80	12	18	(1)

h_{nom} = overall embedment depth in the concrete
 L = length of anchor
 d = diameter of the threaded part of the screw
 d_0 = nominal diameter of drill bit and external diameter of the sleeve
 L_{screw} = length of the screw
 (1) = not prescribed by the producer

Table A2: Materials

Part	Description	Material
1	Cone	Stainless steel acc. to EN 10088-3 (wr. 1.4401-1.4404-1.4571 or equivalent)
2	Sleeve	Stainless steel acc. to EN 10088-2 (Wr. 1.4404)
3	Washer	DIN 125/1 - A4 (or ISO 7089) stainless steel similar acc. to EN 10088-2
4	Hexagonal screw	DIN 933 A4_70 (ISO 3506/1) stainless steel similar acc. to EN 10088-3

FM-MP3[®] evo A4

Product description
Product and materials

Annex A2

Specifications of intended use

Anchorage subjected to:

- Static, quasi static load.

Base materials:

- Cracked and non-cracked concrete.
- Reinforced and unreinforced normal weight concrete of strength class C20/25 at minimum and C50/60 at maximum according to EN 206-1:2000/A2:2005.

Use conditions (Environmental conditions):

- The anchor may be used in concrete subject to dry internal conditions and also in concrete subject to external atmospheric exposure (including industrial and marine environment), or exposure in permanent damp internal conditions, if no particular aggressive conditions exist. Such particular aggressive conditions are e.g. permanent, alternating immersion in seawater or splash zone of seawater, chloride atmosphere of indoor swimming pools or atmosphere with extreme chemical pollution (e.g. desulphurization plants or road tunnels where de-icing materials are used).

Design:

- Anchorages are designed under the responsibility of an engineer experienced in anchorages and concrete work.
- Anchorages under static and quasi-static actions are designed in accordance with ETAG 001, Annex C, design method B, Edition August 2010 or CEN/TS 1992-4-4.
- Verifiable calculation notes and drawings are prepared taking into account of the load to be anchored. The position of the anchor is indicated on the design drawings (e.g. position of the anchor relative to reinforcement or to supports, etc.).
- Fasteners are only to be used for multiple use in non-structural application, according to ETAG 001 Part 6, edition January 2011.

Installation:

- Anchor installation carried out by appropriately qualified personnel and under the supervision of the person responsible for technical matters on the site.
- Use of the anchor only as supplied by the manufacturer without exchanging the components of an anchor.
- Anchor installation in accordance with the manufacturer's specifications and drawings using the appropriate tools.
- Thickness of the fixture corresponding to the range of required thickness values for the type of anchor.
- Checks before placing the anchor to ensure that the strength class of the concrete in which the anchor is to be placed is in the range given and is not lower than that of the concrete to which the characteristic loads apply for.
- Check of concrete being well compacted, e.g. without significant voids.
- Cleaning of the hole of drilling dust.
- Anchor installation ensuring the specified embedment depth.
- Keeping of the edge distance and spacing to the specified values without minus tolerances.
- Positioning of the drill holes without damaging the reinforcement.
- In case of aborted hole: new drilling at a minimum distance away of twice the depth of the aborted hole or smaller distance if the aborted drill hole is filled with high strength mortar and if under shear or oblique tension load it is not to the anchor in the direction of load application.
- Application of the torque moment given in Annex 3 using a calibrated torque wrench.

FM-MP3[®] evo A4

Intended use
Specification

Annex B1

Table B1: Installation data for FM-MP3[®] evo A4

Anchor type		M6	M8	M10	M12
Nominal diameter of drill bit	d_0 [mm]	10	12	15	18
Diameter of clearance hole in the fixture	d_f [mm]	8	10	12	14
Depth of drill hole	$h_1 \geq$ [mm]	60	70	70	100
Minimum thickness of the member	h_{min} [mm]	100	100	100	140
Effective anchorage depth	h_{ef} [mm]	36	43	50	69
Torque moment	T_{inst} [Nm]	8	15	30	50
Thickness of fixture-maximum	t_{fix} [mm]	(2)	(2)	(2)	(2)

$$^{(2)} t_{fix} = L_{screw} - h_{nom}$$

FM-MP3[®] evo A4	Annex B2
Intended use Installation data	

Table C1: **Characteristic values of resistances for design method B acc. ETAG 001 Annex C or CEN/TS1992-4-4**

Essential characteristics			Performance			
			M6	M8	M10	M12
Installation parameters						
d_0	Nominal diameter of drill bit	[mm]	10	12	15	18
h_{ef}	Effective anchorage depth	[mm]	36	43	50	69
h_{min}	Minimum thickness of concrete member	[mm]	100	100	100	140
T_{inst}	Torque moment	[Nm]	8	15	30	50
s_{min}	Minimum spacing	[mm]	35	45	50	75
c_{min}	Minimum edge distance	[mm]	35	45	50	75
Any load direction						
F_{0Rk}	Characteristic resistance in concrete C20/25 to C50/60	[kN]	4	9	12	25
γ_2	Installation safety factor	[-]	1,0			
γ_M	Partial safety factor	[-]	1,5			1,8
F_{0Rd}	Design value in concrete C20/25 to C50/60	[kN]	2,7	6,0	8,0	13,9
s_{cr}	Characteristic spacing	[mm]	200	200	200	280
c_{cr}	Characteristic edge distance	[mm]	100	130	150	210
Shear load with lever arm						
$M_{0Rk,s}^{2)}$	Bending moment characteristic failure	[Nm]	10	26	52	91
$\gamma_{Ms}^{1)}$	Partial safety factor	[-]	1,55			

¹⁾ In absence of other national regulations

²⁾ Characteristic bending resistance $M_{0Rk,s}^0$ according to equation 5.5 in ETAG 001, Annex C

Table C2: **Characteristic values under fire exposure for design acc. to TR020**

			Performance				
			M6	M8	M10	M12	
Fire resistance class							
R30	Characteristic resistance in concrete C20/25 to C50/60	$F_{0Rk,fi}$	[kN]	0,2	0,7	1,5	2,5
R60				0,2	0,6	1,2	2,1
R90				0,1	0,4	0,9	1,7
R120				0,1	0,4	0,8	1,4
R30 to R120	Spacing	$s_{cr,fi}$	[mm]	$\geq 200 \text{ mm and } 4 \times h_{ef}$			
		$s_{min,fi}$		35	45	50	75
	Edge distance	$c_{cr,fi}$	[mm]	$\geq 200 \text{ mm and } 4 \times h_{ef}$			
		$c_{min,fi}$		35	45	50	75

¹⁾ In absence of other national regulations the partial safety factor for resistance under fire exposure $\gamma_{M,fi} = 1,00$ is recommended.

²⁾ For minimum spacing and edge distance depending on minimum thickness of element refer to Table C1 in Annex C1

³⁾ If the fire attack is from more than one side the edge distance of the anchor shall be $c \geq 300 \text{ mm}$

FM-MP3[®] evo A4

Design acc. to ETAG 001-Annex C or CEN/TS 1992-4-4
Characteristic resistance – BWR 1

Annex C1