



ZAVOD ZA  
GRADBENIŠTVO  
SLOVENIJE

SLOVENIAN  
NATIONAL BUILDING  
AND CIVIL ENGINEERING  
INSTITUTE



član EOTA  
Member of EOTA

**Dimičeva 12**  
**1000 Ljubljana, Slovenija**

Tel.: +386 (0)1-280 44 72, 280 45 37

Fax: +386 (0)1-280 44 84

E-pošta: info.ta@zag.si

http://www.zag.si

## European Technical Assessment

**ETA-09/0357**  
**of 28.01.2015**

*English version prepared by ZAG*

### I GENERAL PART

Komercialno ime

*Trade name*

**FM-MP3<sup>®</sup> evo A4**

Imetnik tehnične ocene

*Holder of Technical Assessment*

**FRIULSIDER S.p.A.**

**via Trieste 1**

**33048 San Giovanni al Natisone (UD)**

**Italy**

Družina proizvalca

*Product family*

**Torzijsko kontrolirano zatezno nerjaveče**

**kovinsko sidro velikosti M6, M8, M10 in M12 za**  
**vgradnjo v nerazpokani beton**

*Torque controlled expansion anchor made of stainless steel of*  
*sizes M6, M8, M10 and M12 for use in non-cracked concrete*

Proizvodni obrat

*Manufacturing plant*

**FRIULSIDER S.p.A.**

**via Trieste 1**

**33048 San Giovanni al Natisone (UD)**

**Italy**

Ta Evropska tehnična ocena vsebuje

*This European Technical Assessment*  
*contains*

10 strani vključno s 7 prilogami, ki so sestavni del te ocene

*10 pages including 7 annexes, which form an integral part of the*  
*document*

Ta Evropska tehnična ocena je izdana na podlagi Uredbe (EU) št. 305/2011 na osnovi

*This European Technical Assessment is*  
*issued in accordance to Regulation (EU)*  
*No 305/2011, on the basis of*

Smernice za evropska tehnična soglasja ETAG 001 – del 1 in 2, izdaja 2013, ki se uporablja kot EAD

*Guideline for European Technical Approval ETAG 001 – part 1*  
*and 2, edition 2013, used as EAD*

Ta ocena zamenjuje

*This Assessment replaces*

ETA-09/0357 izdano dne 08.05.2013

ETA-09/0357 issued on 08.05.2013

Translations of this European Technical Assessment in other languages shall fully correspond to the original issued document and should be identified as such.

Communication of this European Technical Assessment, including transmission by electronic means, shall be in full (excepted the confidential Annex(es) referred to above). However, partial reproduction may be made, with the written consent of the issuing Technical Assessment Body. Any partial reproduction has to be identified as such.

## **II SPECIFIC PART OF THE EUROPEAN TECHNICAL ASSESSMENT**

### **1 Technical description of the product**

The FM-MP3<sup>®</sup> evo A4 in the range of M6, M8, M10 and M12 is an anchor made of stainless steel, which is placed into a drilled hole and anchored by torque-controlled expansion.

For the installed anchor see Figure given in Annex A1.

### **2 Specification and intended use**

The performances given in Chapter 3 are only valid if the anchor is used in compliance with the specifications and conditions given in Annex B.

The provisions made in this European Technical Assessment are based on an assumed working life of the anchor of 50 years. The indications given on the working life cannot be interpreted as a guarantee given by the manufacturer, but are to be regarded only as a means for choosing the right products in relation to the expected economically reasonable working life of the works.

### **3 Performance of the product and references to the methods used for this assessment**

#### **3.1 Mechanical resistance and stability (BWR 1)**

The basic work requirements for mechanical resistance and stability are listed in Annexes C1 and C2.

#### **3.2 Safety in case of fire (BWR 2)**

No performance determined.

#### **3.3 Hygiene, health and environment (BWR 3)**

Regarding dangerous substances contained in this European Technical Assessment, there may be requirements applicable to the products falling within its scope (e.g. transported European legislation and national laws, regulations and administrative provisions). In order to meet provisions of the regulation (EU) No 305/2011, these requirements need also to be complied with, when they apply.

#### **3.4 Safety in use (BWR 4)**

For basic work requirement safety in use the same criteria are valid as for basic work requirement mechanical resistance and stability.

#### **3.5 Protection against noise (BWR 5)**

Not relevant.

#### **3.6 Energy economy and heat retention (BWR 6)**

Not relevant.

#### **3.7 Sustainable use of natural resources (BWR 7)**

No performance determined.

#### **3.8 General aspects relating to fitness for use**

Durability and serviceability are only ensured if specifications of intended use according to Annex B1 are kept.

#### 4 Assessment and verification of constancy of performance

According to the decision 96/582/EC of the European Commission<sup>1</sup> the system of assessment and verification of constancy of performance (see Annex V to regulation (EU) No 305/2011) given in the following table apply.

Product	Intended use	Level of class	System
Metal anchors for use in concrete	For fixing and/or supporting to concrete, structural elements (which contributes to the stability of the works) or heavy units	-	1

#### 5 Technical details necessary for the implementation of the AVCP system

##### 5.1 Tasks for the manufacturer

The manufacturer shall exercise permanent internal control of production of concerned product. All the elements, requirements and provisions adopted by the manufacturer shall be documented in a systematic manner in the form of written policies and procedures, including records of results performed. This production control system shall ensure that the product is in conformity with this European Technical Assessment.

The manufacturer may only use raw materials stated in the technical documentation of this European Technical Assessment.

The factory production control shall be in accordance with the Control plan which is a part of the technical documentation of this European Technical Assessment. The Control plan<sup>2</sup> is laid down in the context of the factory production control system operated by the manufacturer and deposited at Slovenian National Building and Civil Engineering Institute (ZAG Ljubljana). The results of factory production Control shall be recorded and evaluated in accordance with the provisions of the control plan.

The manufacturer shall, on the basis of a contract, involve a body, which is notified for the tasks referred to in a section 4 in the field of anchors in order to undertake the actions laid down in section 5.2. For this purpose the Control plan referred to in sections 5.1 and 5.2 shall be handed over by the manufacturer to the notified body involved.

The manufacturer shall make a Declaration of performance, stating that the construction product is in conformity with the provisions of this European Technical Assessment.

---

<sup>1</sup> Official Journal of the European Communities L 254 of 8.10.1996

<sup>2</sup> The Control plan is a confidential part of the technical documentation of this European Technical Assessment, but not published together with the ETA, and handed over only to the notified body or bodies involved in the procedure of attestation of conformity.

## **5.2 Tasks for the notified bodies**

The notified body shall retain the essential points of its actions defined in Annex V of Regulation (EU) No. 305/2011 for system 1 and state results obtained and conclusions drawn in a written report.

The notified certification body involved by the manufacturer shall issue an EC certificate of constancy of performance the product stating the conformity with the provisions of this European Technical Assessment.

In cases where the provisions of the European Technical Assessment and its Control plan are no longer fulfilled the notified body shall withdraw the certificate of constancy of performance and inform the Slovenian National Building and Civil Engineering Institute (ZAG Ljubljana) without delay.

Issued in Ljubljana on 28.01.2015

Signed by:

Franc Capuder, M.Sc., Research Engineer

*Head of Service of TAB*

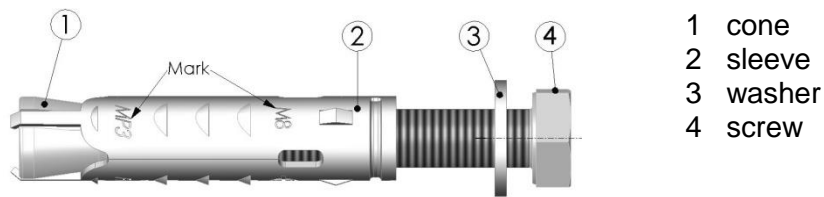

**Figure A1:** FM-MP3® evo A4 anchor

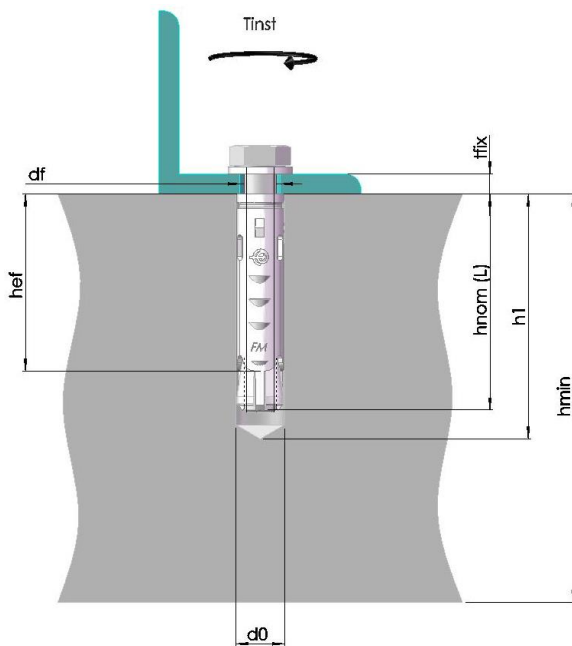

**Figure A2:** Installed FM-MP3® evo A4 anchor

**FM-MP3® evo A4**

**Product description**

Product and intended use

**Annex A1**

**Table A1:** Dimensions of different parts of an anchor

Anchor type	$h_{nom}$ (mm)	L (mm)	d (mm)	$d_0$ (mm)	$L_{screw}$ (mm)
FM-MP3 <sup>®</sup> evo A4 M6	45	45	6	10	(1)
FM-MP3 <sup>®</sup> evo A4 M8	50	50	8	12	(1)
FM-MP3 <sup>®</sup> evo A4 M10	60	60	10	15	(1)
FM-MP3 <sup>®</sup> evo A4 M12	80	80	12	18	(1)

$h_{nom}$  = overall embedment depth in the concrete  
 L = length of anchor  
 d = diameter of the threaded part of the screw  
 $d_0$  = nominal diameter of drill bit and external diameter of the sleeve  
 $L_{screw}$  = length of the screw  
 (1) = not prescribed by the producer

**Table A2:** Materials

Part	Description	Material
1	Cone	Stainless steel acc. to EN 10088-3 (wr. 1.4401-1.4404-1.4571 or equivalent)
2	Sleeve	Stainless steel acc. to EN 10088-2 (Wr. 1.4404)
3	Washer	DIN 125/1 - A4 (or ISO 7089) stainless steel similar acc. to EN 10088-2
4	Hexagonal screw	DIN 933 A4_70 (ISO 3506/1) stainless steel similar acc. to EN 10088-3

**FM-MP3<sup>®</sup> evo A4**

**Product description**  
Product and materials

**Annex A2**

**Specifications of intended use**

**Anchorage subjected to:**

- Static, quasi static load.

**Base materials:**

- Non-cracked concrete.
- Reinforced and unreinforced normal weight concrete of strength class C20/25 at minimum and C50/60 at maximum according to EN 206-1:2000/A2:2005.

**Use conditions (Environmental conditions):**

- The anchor may be used in concrete subject to dry internal conditions and also in concrete subject to external atmospheric exposure (including industrial and marine environment), or exposure in permanent damp internal conditions, if no particular aggressive conditions exist. Such particular aggressive conditions are e.g. permanent, alternating immersion in seawater or splash zone of seawater, chloride atmosphere of indoor swimming pools or atmosphere with extreme chemical pollution (e.g. desulphurization plants or road tunnels where de-icing materials are used).

**Design:**

- Anchorages are designed under the responsibility of an engineer experienced in anchorages and concrete work.
- Anchorages under static and quasi-static actions are designed in accordance with ETAG 001, Annex C, design method A, Edition August 2010 or CEN/TS 1992-4-4.
- Verifiable calculation notes and drawings are prepared taking into account of the load to be anchored. The position of the anchor is indicated on the design drawings (e.g. position of the anchor relative to reinforcement or to supports, etc.).

**Installation:**

- Anchor installation carried out by appropriately qualified personnel and under the supervision of the person responsible for technical matters on the site.
- Use of the anchor only as supplied by the manufacturer without exchanging the components of an anchor.
- Anchor installation in accordance with the manufacturer's specifications and drawings using the appropriate tools.
- Thickness of the fixture corresponding to the range of required thickness values for the type of anchor.
- Checks before placing the anchor to ensure that the strength class of the concrete in which the anchor is to be placed is in the range given and is not lower than that of the concrete to which the characteristic loads apply for.
- Check of concrete being well compacted, e.g. without significant voids.
- Cleaning of the hole of drilling dust.
- Anchor installation ensuring the specified embedment depth.
- Keeping of the edge distance and spacing to the specified values without minus tolerances.
- Positioning of the drill holes without damaging the reinforcement.
- In case of aborted hole: new drilling at a minimum distance away of twice the depth of the aborted hole or smaller distance if the aborted drill hole is filled with high strength mortar and if under shear or oblique tension load it is not to the anchor in the direction of load application.
- Application of the torque moment given in Annex 3 using a calibrated torque wrench.

**FM-MP3<sup>®</sup> evo A4**

**Intended use**  
Specification

**Annex B1**

Table 3: Installation data

Anchor type		M6	M8	M10	M12
Nominal diameter of drill bit	$d_0$ [mm]	10	12	15	18
Diameter of clearance hole in the fixture	$d_f$ [mm]	8	10	12	14
Depth of drill hole	$h_1 \geq$ [mm]	60	70	70	100
Minimum thickness of the member	$h_{min}$ [mm]	100	100	100	140
Effective anchorage depth	$h_{ef}$ [mm]	36	43	50	69
Torque moment	$T_{inst}$ [Nm]	8	15	30	50
Thickness of fixture-maximum	$t_{fix}$ [mm]	(2)	(2)	(2)	(2)

(2)  $t_{fix} = L_{screw} - h_{nom}$

**FM-MP3<sup>®</sup> evo A4**

**Intended use**  
Installation data

**Annex B2**

Table C1: **Characteristic values for Tension loads in case of static and quasi-static loading for design method A acc. ETAG 001-Annex C or CEN/TS1992-4-4**

Essential characteristics			Performance			
			M6	M8	M10	M12
<b>Installation parameters</b>						
$d_0$	Nominal diameter of drill bit	[mm]	10	12	15	18
$h_{ef}$	Effective anchorage depth	[mm]	36	43	50	69
$h_{min}$	Minimum thickness of concrete member	[mm]	100	100	100	140
$T_{inst}$	Torque moment	[Nm]	8	15	30	50
$s_{min}$	Minimum spacing	[mm]	35	45	50	75
$c_{min}$	Minimum edge distance	[mm]	35	45	50	75
<b>Tension steel failure mode</b>						
$N_{Rk,s}$	Characteristic tension steel failure	[kN]	14	25	40	59
$\gamma_{MsN}$	Partial safety factor	[-]	1,87			
<b>Pull-out failure mode</b>						
$N_{Rk,p}$	Characteristic pull-out failure in non-cracked concrete	[kN]	6	12	16	25
$\gamma_2$	Partial safety factor	[-]	1,2			
$\gamma_{Mp}$		[-]	1,8			
$s_{cr,N}$	Characteristic spacing	[mm]	108	129	150	207
$c_{cr,N}$	Characteristic edge distance	[mm]	54	65	75	104
$\psi_C C30/37$	Increasing factor for $N_{Rk,p}$ in non-cracked concrete	[-]	1,22			
$\psi_C C40/50$		[-]	1,41			
$\psi_C C50/60$		[-]	1,55			
<b>Concrete Cone failure mode</b>						
$k_{ucr}$	Factor for un-cracked concrete CEN/TS 1992-4-4 §. 6.2.1.4	[-]	10,1			
$\gamma_{Mc}$	Partial safety factor	[-]	1,8			
<b>Splitting failure mode</b>						
$s_{cr,sp}$	Characteristic spacing	[mm]	216	258	300	414
$c_{cr,sp}$	Characteristic edge distance	[mm]	108	130	150	208
$\gamma_{Msp}$	Partial safety factor	[-]	1,8			
<b>Displacement under tension load</b>						
Non-cracked concrete C20/25						
$N$	Service tension load	[kN]	2,4	4,8	6,4	9,9
$\delta_{N0}$	Short term displacement	[mm]	0,02	0,11	0,03	0,01
$\delta_{N\infty}$	Long term displacement	[mm]	0,95	0,95	0,95	0,95

FM-MP3<sup>®</sup> evo A4Design acc. to ETAG 001-Annex C or CEN/TS 1992-4-4  
Characteristic resistance under Tension loads – BWR 1

Annex C1

Table C2: **Characteristic values for Shear loads in case of static and quasi-static loading for design method A acc. ETAG 001-Annex C or CEN/TS 1992-4-4**

Essential characteristics			Performance			
			M6	M8	M10	M12
<b>Shear steel failure</b>						
$V_{Rk,s}$	Characteristic shear steel failure	[kN]	7	12	20	29
$M^0_{Rk,s}$	Bending moment characteristic failure	[Nm]	10	26	52	91
$K_2$	Factor considering ductility	[-]	0,8			
$\gamma_{MsV}$	Partial safety factor	[-]	1,55			
<b>Shear concrete pry-out and edge failure</b>						
$k$	Factor in equation (5.6) of ETAG 001 Annex C § 5.2.3.3	[mm]	1,0			2,0
$K_3$	Factor in equation (16) of CEN/TS 1992-4-4 § 6.2.2.3	[mm]	1,0			2,0
$l_{ef}$	Effective anchorage depth	[mm]	36	43	50	69
$d_{nom}$	Diameter of anchor	[mm]	10	12	15	18
$\gamma_{Mc}$	Partial safety factor	[-]	1,8			
<b>Displacement under shear load</b>						
$V$	Service shear load	[kN]	3,2	5,9	9,3	13,6
$\delta_{V0}$	Short term displacement	[mm]	0,85	1,37	1,21	1,24
$\delta_{V\infty}$	Long term displacement	[mm]	1,28	2,06	1,82	1,86

FM-MP3<sup>®</sup> evo A4

Design acc. to ETAG 001-Annex C or CEN/TS 1992-4-4  
Characteristic resistance under Shear loads – BWR 1

Annex C2