



ZAVOD ZA  
GRADBENIŠTVO  
SLOVENIJE

SLOVENIAN  
NATIONAL BUILDING  
AND CIVIL ENGINEERING  
INSTITUTE



Member of  
[www.eota.eu](http://www.eota.eu)

**Dimičeva 12,  
1000 Ljubljana, Slovenija**

Tel.: +386 (0)1 280 44 72, +386 (0)1-280 45 37

Fax: +386 (0)1 280 44 84

e-mail: [info.ta@zag.si](mailto:info.ta@zag.si)

<http://www.zag.si>

## European Technical Assessment

**ETA-22/0792**  
of 29.5.2023

*English version prepared by ZAG*

### General Part

<b>Technical Assessment Body issuing the European Technical Assessment</b>	<b>ZAG</b>
<b>Trade name of the construction product</b>	<b>FM 753 evo</b>
<b>Product family to which the construction product belongs</b>	<b>33: Torque controlled expansion anchor made of zinc coated steel for use in non-cracked concrete</b>
<b>Manufacturer</b>	<b>FRIULSIDER S.p.A. via Trieste 1 33048 San Giovanni al Natisone (UD) Italy <a href="http://www.friulsider.com">www.friulsider.com</a></b>
<b>Manufacturing plant</b>	<b>FRIULSIDER S.p.A. via Trieste 1 33048 San Giovanni al Natisone (UD) Italy</b>
<b>This European Technical Assessment contains</b>	<b>9 pages including 3 annexes, which form an integral part of the document</b>
<b>This European Technical Assessment is issued in according to Regulation (EU) No 305/2011, on the basis of</b>	<b>EAD 330232-01-0601, edition December 2019</b>

Translations of this European Technical Assessment in other languages shall fully correspond to the original issued document and should be identified as such.

Communication of this European Technical Assessment, including transmission by electronic means, shall be in full (excepted the confidential Annex(es) referred to above). However, partial reproduction may be made, with the written consent of the issuing Technical Assessment Body. Any partial reproduction has to be identified as such.

## Specific Parts

### 1 Technical description of the product

The FM-753 evo of sizes M6, M8, M10, M12 and M16 is an anchor made of galvanised steel, which is placed into a drilled hole and anchored by torque-controlled expansion.

The product description is given in Annex A (1/2) and A (2/2).

### 2 Specification of the intended use(s) in accordance with the applicable European Assessment Document (hereinafter EAD)

The performances given in Chapter 3 are only valid if the anchor is used in compliance with the specifications and conditions given in Annex B.

The provisions made in this European Technical Assessment are based on an assumed working life of the anchor of 50 years. The indications given on the working life cannot be interpreted as a guarantee given by the manufacturer, but are to be regarded only as a means for choosing the right products in relation to the expected economically reasonable working life of the works.

### 3 Performance of the product and references to the methods used for this assessment

#### 3.1 Mechanical resistance and stability (BWR 1)

The basic work requirements for mechanical resistance and stability are listed in Annexes C (1/2) and C (2/2).

#### 3.2 Safety in case of fire (BWR 2)

No performance assessed.

#### 3.8 General aspects relating to fitness for use

Durability and serviceability are only ensured if specifications of intended use according to Annex B (1/2), B(2/3) and B(3/3) are kept.

### 4 Assessment and verification of constancy of performance (hereinafter AVCP) system applied, with reference to its legal base

According to the decision 96/582/EC of the European Commission<sup>1</sup> the system of assessment and verification of constancy of performance (see Annex V to regulation (EU) No 305/2011) 1 apply.

### 5 Technical details necessary for the implementation of the AVCP system, as provided for on the applicable EAD

Technical details necessary for the implementation of the AVCP system are laid down in chapter 3 of EAD 330232-01-0601.

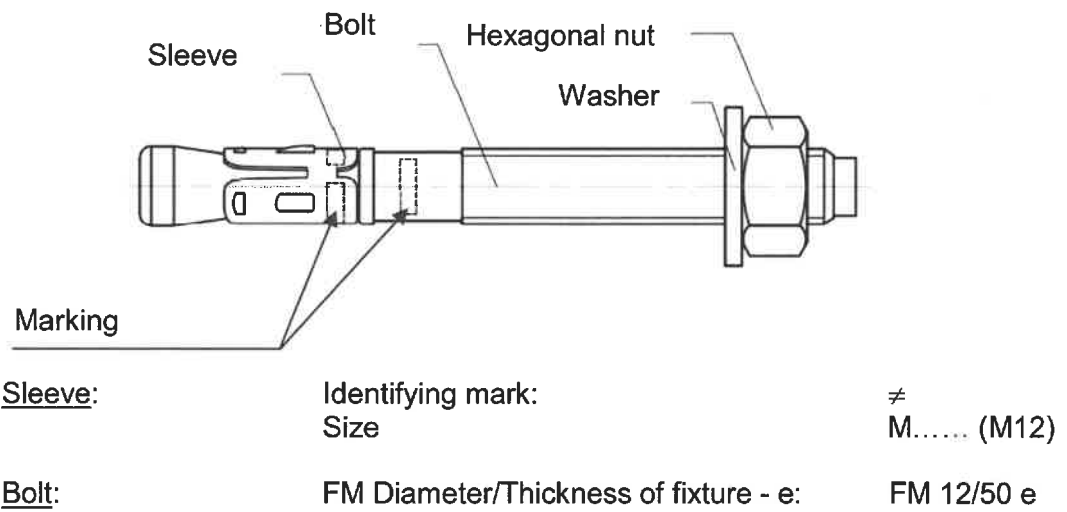
Issued in Ljubljana on 29.5.2023

Signed by:

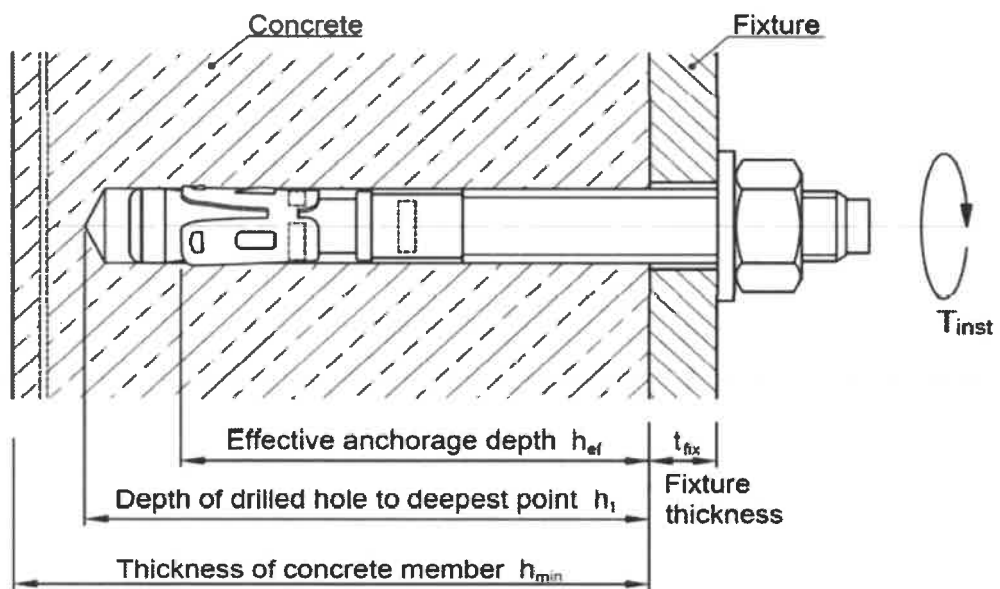
Franc Capuder, M.Sc., Research Engineer

Head of Service of TAB

<sup>1</sup> Official Journal of the European Communities L 254 of 8.10.1996

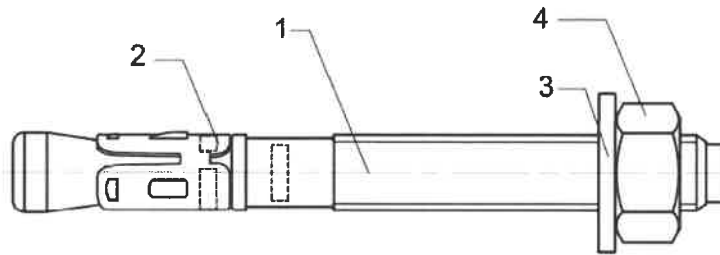


**Figure A1:** FM 753 evo anchor



**Figure A2:** Installed FM 753 evo anchor

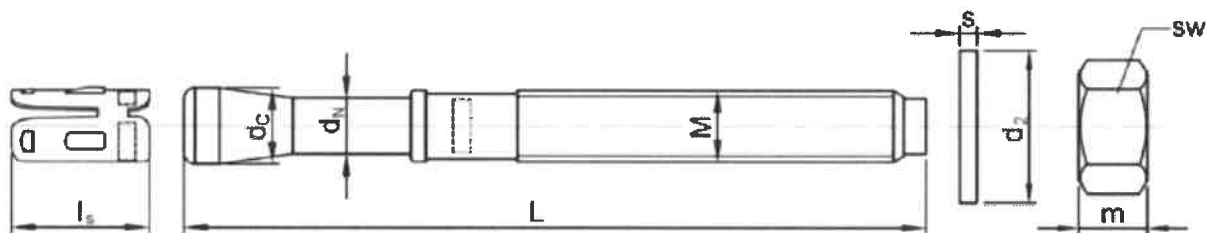
<b>FM 753 evo</b>	<b>Annex A (1/2)</b>
<b>Product description</b> Product, marking and installation condition	



**Table A1: Materials**

Part	Component	Material <sup>1)</sup>
1	Bolt	Carbon steel, turned and cold formed
2	Sleeve	Carbon steel streep, cold formed
3	Washer	Steel; DIN 125 (EN ISO 7089), DIN 440 (EN ISO 7094) DIN 9021 (EN ISO 7093)
4	Hexagonal nut	Steel DIN 934 (EN ISO 4032, Property class 8 acc. EN 20898-2)

<sup>1)</sup> zinc electroplated  $\geq 5 \mu\text{m}$  according to EN ISO 4042; passivated



**Table A2: Dimensions**

Anchor type / size	L	M	d <sub>c</sub>	d <sub>N</sub>	l <sub>s</sub>	s	d <sub>2</sub>	m	SW
	[mm]		[mm]	[mm]	[mm]	[mm]	[mm]	[mm]	[mm]
FM 753 evo/6	t <sub>fix</sub> +55	M6	6,00	4,3	12,5	$\geq 1,6$	$\geq 12$	5,0	10
FM 753 evo/8	t <sub>fix</sub> +63	M8	8,00	5,9	15,0	$\geq 1,6$	$\geq 16$	6,5	13
FM 753 evo/10	t <sub>fix</sub> +73	M10	10,00	7,6	16,8	$\geq 2,0$	$\geq 20$	8,0	17 (16)
FM 753 evo/12	t <sub>fix</sub> +99	M12	11,95	8,8	20,0	$\geq 2,5$	$\geq 24$	10,0	19 (18)
FM 753 evo/16	t <sub>fix</sub> +121	M16	15,95	12,0	22,6	$\geq 3,0$	$\geq 30$	13,0	24

**FM 753 evo**

**Product description**  
Dimensions and materials

**Annex A (2/2)**

### **Specifications of intended use**

#### **Anchorage subjected to:**

- Static and quasi static action.

#### **Base materials:**

- Non-cracked concrete.
- Reinforced and unreinforced normal weight concrete of strength class C20/25 at minimum and C50/60 at maximum according to EN 206:2013+A2:2021.

#### **Use conditions (Environmental conditions):**

- The anchor may be used in concrete subject to dry internal conditions.

#### **Design:**

- Anchorages are designed under the responsibility of an engineer experienced in anchorages and concrete work.
- Anchorages under static and quasi-static actions are designed in accordance EN 1992-4:2018.
- Verifiable calculation notes and drawings are prepared taking into account of the load to be anchored. The position of the anchor is indicated on the design drawings (e.g. position of the anchor relative to reinforcement or to supports, etc.).

#### **Installation:**



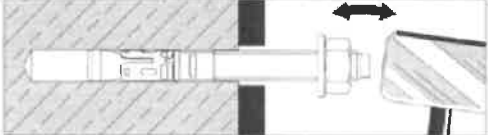
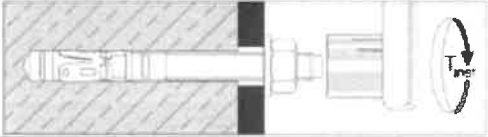
- Anchor installation carried out by appropriately qualified personnel and under supervision of the person responsible for technical matters of the site.
- Use of the anchor only supplied by the manufacturer without exchanging the components of an anchor.
- Anchor installation in accordance with the manufacturer's specification and drawings and using the appropriate tools.
- Checks before placing the anchor to ensure that the strength class of the concrete in which the anchor is to be placed is in the range given and is not lower than that of the concrete to which the characteristic loads apply for.
- Check of concrete being well compacted, e.g. without significant voids.
- Effective anchorage depth, edge distances and spacing not less than the specified values without minus tolerances.
- Hole drilling by hammer drill.
- Cleaning of the hole of drilling dust.
- Positioning of the drill holes without damaging the reinforcement.
- Application of specified torque moment using a calibrated torque wrench.
- In case of aborted hole, drilling of new hole at a minimum distance of twice the depth of the aborted hole, or smaller distance provided the aborted drill hole is filled with high strength mortar and no shear or oblique tension loads in the direction of aborted hole.

<b>FM 753 evo</b>	<b>Annex B (1/3)</b>
<b>Intended use Specifications</b>	

**Table B1:** Installation data

FM 753 evo			Anchor size				
			M6	M8	M10	M12	M16
Max. total length	L	[mm]	100	163	233	369	321
Diameter of drill bit	d <sub>0</sub>	[mm]	6	8	10	12	16
Cutting diameter at the upper tolerance limit	d <sub>cut,max</sub> ≤	[mm]	6,45	8,45	10,45	12,50	16,50
Effective anchorage depth	h <sub>ef</sub>	[mm]	40	45	50	65	80
Depth of drilled hole	h <sub>1</sub> ≤	[mm]	55	65	70	90	110
Diameter of clearance hole	d <sub>f</sub> ≤	[mm]	7	9	12	14	18
Maximum thickness of the fixture	t <sub>fix,max</sub>	[mm]	45	100	160	270	200
Installation torque	T <sub>inst</sub>	[Nm]	8	15	30	50	100
Width across flats	SW	[mm]	10	13	17(16)	19(18)	24
Minimum thickness of concrete member	h <sub>min</sub>	[mm]	100	100	100	130	160
Minimum spacing	s <sub>min</sub>	[mm]	30	40	50	70	90
Minimum edge distance	c <sub>min</sub>	[mm]	40	40	50	70	90

<b>FM 753 evo</b>	<b>Annex B (2/3)</b>
<b>Intended use</b> Installation data minimum spacing and edge distance	

	<p>Drill hole perpendicular to concrete surface.</p>
	<p>Blow out dust. Alternatively vacuum cleaning down to the bottom of the hole.</p>
	<p>Insert the anchor through the fixture.</p>
	<p>Apply installation torque <math>T_{inst}</math> using an calibrated torque-wrench.</p>

<b>FM 753 evo</b>	<b>Annex B (3/3)</b>
<b>Intended use</b> Installation instructions	

**Table C1:** Characteristic values for tension loads in case of static and quasi-static loading for design method A acc. to EN 1992-4:2018

Essential characteristics			Performance				
			M6	M8	M10	M12	M16
<b>Installation parameters</b>							
$d_0$	Nominal diameter of drill bit	[mm]	6	8	10	12	16
$h_{ef}$	Effective anchorage depth	[mm]	40	45	50	65	80
$h_{min}$	Minimum thickness of concrete member	[mm]	100	100	100	130	160
$T_{inst}$	Torque moment	[Nm]	8	15	30	50	100
$s_{min}$	Minimum spacing	[mm]	30	40	50	70	90
$c_{min}$	Minimum edge distance	[mm]	40	40	50	70	90
<b>NRk,s</b>							
$N_{Rk,s}$	Characteristic tension steel failure	[kN]	10,9	20,5	32,3	45,6	79,2
$\gamma_{MsN}$	Partial safety factor	[-]	1,4				
<b>Pull-out failure mode</b>							
$N_{Rk,p}$	Characteristic pull-out failure in non-cracked concrete	[kN]	6,0	12,0	17,4	25,8	35,2
$\gamma_{inst}$	Partial safety factor	[-]	1,0				
$\gamma_{Mp}$		[-]	1,5				
$s_{cr,N}$	Characteristic spacing	[mm]	3 x $h_{ef}$				
$c_{cr,N}$	Characteristic edge distance	[mm]	1,5 x $h_{ef}$				
$\psi_c$ C30/37	Increasing factor for $N_{Rk,p}$ in non-cracked concrete	[-]	1,01	1,04	1,22	1,21	1,15
$\psi_c$ C40/50		[-]	1,01	1,06	1,41	1,39	1,27
$\psi_c$ C50/60		[-]	1,02	1,09	1,58	1,55	1,38
<b>Concrete Cone failure mode</b>							
$k_{ucr}$	Factor for un-cracked concrete EN 1992-4:2018 § 7.2.1.4	[-]	11				
$\gamma_{Mc}$	Partial safety factor	[-]	1,5				
<b>Splitting failure mode</b>							
$s_{cr,sp}$	Characteristic spacing	[mm]	160	225	250	360	400
$c_{cr,sp}$	Characteristic edge distance	[mm]	80	112,5	125	180	200
$\gamma_{MsP}$	Partial safety factor	[-]	1,5				
<b>Displacement under tension load</b>							
Non-cracked concrete C20/25							
$N$	Service tension load	[kN]	3,1	6,1	8,9	13,2	18,0
$\delta_{N0}$	Short term displacement	[mm]	0,08	0,14	0,15	1,15	0,14
$\delta_{N\infty}$	Long term displacement	[mm]	3,19	3,19	3,19	3,19	3,19

**FM 753 evo**

**Performance**

Characteristic resistance under tension load

**Annex C (1/2)**

**Table C2:** Characteristic values for shear loads in case of static and quasi-static loading for design method A acc. to EN 1992-4:2018

Essential characteristics			Performance				
			M6	M8	M10	M12	M16
<b>Steel failure without lever arm</b>							
$V_{Rk,s}$	Characteristic resistance	[kN]	6,4	9,9	17,4	25,1	46,9
$\gamma_{Ms}$	Partial safety factor	[Nm]	1,25				
$k_7$	Factor for considering ductility	[-]	1,0				
<b>Steel failure with lever arm</b>							
$M^0_{Rk,s}$	Characteristic resistance	[Nm]	11	28	56	98	233
$\gamma_{Ms}$	Partial safety factor	[mm]	1,25				
<b>Concrete pryout failure</b>							
$k_8$	k-factor	[-]	1,0			2,0	
$\gamma_{Mc}$	Partial safety factor	[-]	1,5				
<b>Concrete edge failure</b>							
$l_{ef}$	Effective length of anchor under shear load	[mm]	40	45	50	65	80
$d_{nom}$	Outside diameter of anchor	[mm]	6	8	10	12	16
$\gamma_{Mc}$	Partial safety factor	[-]	1,5				
<b>Displacement under shear load</b>							
$V$	Service shear load	[kN]	3,6	5,6	9,9	16,4	26,8
$\delta_{v0}$	Short term displacement	[mm]	0,84	1,06	3,40	1,56	2,18
$\delta_{v\infty}$	Long term displacement	[mm]	1,26	1,59	5,10	2,34	3,27

**FM 753 evo**

**Performance**

Characteristic resistance under shear load

**Annex C (2/2)**