

Manufacturer: ETANCO (FRANCE)

Parc les Erables – Bât 1 – 66 route de Sartrouville – BP 49 – 78231 LE PECQ Cedex

Tel.: +33 (0)1 34 80 52 00 – Fax: +33 (0)1 30 71 01 89

Product name:

FAT 15 TH12/ 2C Ø 6 x L

Application:

Steel sheet on steel beam

Description:

Self-drilling screws Ø 6 mm

Hexagonal Head of 12 mm o moulded colour plastic

Pitch = 1.2mm. Drill point

Can be mounted with VULCA Aluminium washer Ø14 mm

Drilling Capacity (CP) :

4 to 15 mm into sheet steel

Material :

Screw Body: Cemented steel 20MB5 - SAE 1020 - JIS SWRCH22A.

Surface hardness: HV0.5 _ 550 < HV < 750

Screw head: Polyamide of colour

Washer: Aluminium + 2 mm thick glued vulcanised EPDM, 70 Shore A

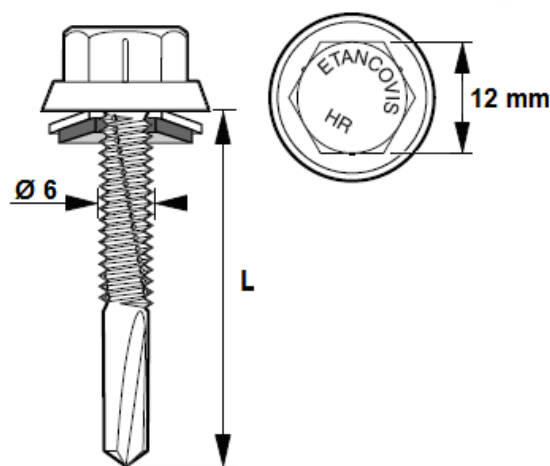

Not contractual position marking

Material, coating and corrosion resistance tests:

- **2C: SUPRACOAT 2C** treated cemented steel (12 to 20 µm)

Corrosion resistance level determined by Kesternich test (sulphur dioxide corrosion with general dampness condensation) according to NF EN 3231 (2 l):

Resisted to 15 cycles before the appearance of red rust

Salt spray test according to NF ISO 9227 (March 2007):

Screw body: No trace of red rust after 500 hours.

Screw head: No trace of red rust after 1000 hours.

Screw head resistance to corrosion:

(20 years anti-corrosion guarantee)

Drilling Time Performance:

- Conditions: a) Test material : Structural steel S355 JR
 b) Tools used : Drilling test with SCS Fein 6.3-19X power 400 W mini with torque limiter and depth control

Drilling test	Unit	Ø 4.8	Ø 5.5	Ø 6.3 & 6.5
Drilling Time	s/mm	< 2	< 2	< 2
Speed rotate	Rpm	2000 *	2000 *	2000 *
Axial load	dan	16	20	27

* Under load: 1800 rotations/min

Drilling Capacity, diameter, length (in mm) and packaging:

Capacity CP Drilling	Ø x Length	Capacity of tightening CS mini	Assembly Capacity CA maxi	Hex Head TH	Packaging
4 to 15	6 x 35 + VA 14	-	12	12	100
4 to 15	6 x 45 + VA 14	-	22	12	100
4 to 15	6 x 55	14	34	12	100

Tensile test value (value in daN):

$\bar{x} = 1294 \text{ daN}$



Shear test value – 0.6 x Rm (value in daN):

$\bar{x} = 776 \text{ daN}$

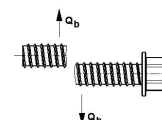

Breaking torque value (in Nm):

$\bar{x} = 15 \text{ Nm}$

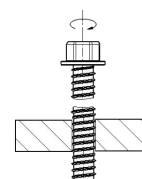

Pull out test values (Pk in daN) of top sheet - According to NF P 30-314

Top Sheet S320 Steel	Sheet thickness (mm)					
	Support Sheet Steel S235					
0.75 mm	4 mm	6 mm	8 mm	10 mm	12 mm	15 mm
	475 *	475*	475*	475*	475*	475*

The values indicated do not include safety factors

***Buckling**

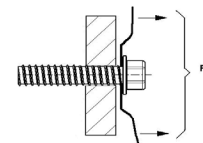

Pull out test values (Pk in daN) – According to NF P 30-310

Support Thickness (mm)					
S235 Steel					
4 mm	6 mm	8 mm	10 mm	12 mm	15 mm
819	1062	1780**	1780**	1780**	1780**

The values indicated do not include safety factors

****Break up**

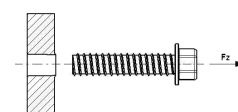

Shear load test values (Pk in daN) – According to NF P 30-316

Sheet thickness (mm)		
Top Plate S320 Steel	Support Sheet Steel S235	dan
0.75	4	-
0.75	6	-
0.75	8	-
0.75	10	-
0.75	12	-
0.75	15	-

The values indicated do not include safety factors

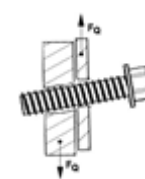

Conformity:

French professional regulations related to cladding

Recommended setting tools:

Screwing toll FEIN SCS 6.3 -19X power 400 W mini with torque limiter and depth control
Screw Tip : socket with 12 mm imprint hex head hollow

Marking - Labelling :

FAT 15 TH12 / 2C – Ø 6 x L + code
FAT 15 TH12 / 2C – Ø 6 x L + VA 14 + code

Quality Control :

ISO 9001:2015