

CANAL-DRILLNOX 12 TH8 A4 Ø 6,3 x 120 + VULCA WASHER Ø 30



PRODUCT DEFINITION

- Self-drilling screw Ø 6.3 mm bi-metal.
- Pre-assembled with VULCA washer Ø 30 (code: 299 881).
- Hex head of 8 mm.
- Ø 13 mm flange.
- A4 stainless steel.
- Body with fins replacing the pre-drilling (Ø8.6 mm).
- 1.81 mm pitch.
- Drill point.

APPLICATION

- Roofing: Fastening of channel tile support plates (PST) without pre-drilling to steel frames.
- Very aggressive environment (off the seafront).
- Drilling capacity (CP): 4 to 12 mm of steel.

MATERIAL & COATING

Material :

- Screw body: Austenitic stainless steel A4 – 1.4404 - AISI 316L.
- Drill point and first threads: Treated carbon steel.
- VULCA washer: A2 (VI) stainless steel + EPDM (Ethylene Propylene Diene Monomer)

Corrosion resistance:

- Screw Body:
 - By Kesternich test according to NF EN ISO 3231:
Resist to more 30 cycles without the appearance of red rust.
 - By salt spray test according to NF EN ISO 9227:
No trace of red rust after 1000 hours.
- Steel tip and 1st threads with surface coating:
 - By salt spray test according to NF EN ISO 9227:
No trace of red rust after 200 hours.

INSTALLATION

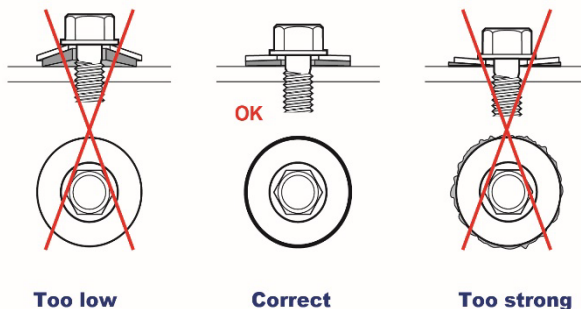

- The assembly is done out using a FEIN ASCM 18-4 QM AS screwdriver with torque limiter and depth gauge with an 8 mm hexagonal socket.

Unauthorized machines:

- Nutrunners, impact wrenches, impact drivers are not suitable for assembly work and are strictly forbidden to use.

Recommended tools:

- FEIN ASCM 18-4 QM AS battery-powered screwdriver set + 2 batteries and 1 charger (code: 321 688).
- Depth stop for FEIN ASCM 18-4 QM AS (code: 321 686).
- 3rd Hand Set for TH8 Screws (Code: 320 153).
- 8mm LG 65mm Hex Socket (Code: 323 500).

Associated Products:

- CANAL-DRILLNOX 4 TH8 A2 Ø 6.3 x 105 + VULCA WASHER Ø 30 (refer to TDS no. 4572).
- CANAL-DRILLNOX 4 TH8 A4 Ø 6.3 x 105 + VULCA WASHER Ø 30 (refer to TDS no. 4035).
- CANAL-DRILLNOX 12 TH8 A2 Ø 6.3 x 120 + VULCA WASHER Ø 30 (refer to TDS no. 4573).
- CLOSER for CP tile support plates (refer to roofing booklet)
- ETANCOPAST waterproofing sealant (code: 443 090)

PERFORMANCE

Mechanical properties of the EPDM of the VULCA washer:

- **Hardness** : 58 ± 5 SHORE A + ANTI-UV.

Drilling time :

- **Materials tested** : S355 JR structural steel.
- **Tools used** : FEIN ASCM 18-4 QM AS screwdriver with torque limiter and depth gauge.

Drilling test	Unit	Ø 6.3
Drilling Time	dry/mm	< 2
Rotational speed	RPM	2000 *
Axial load	dan	27

(*) Actual under load: 1800 rpm

Characteristic resistances:

- Characteristic tensile Strength: $\bar{x} = 1076 \text{ daN}$



- Characteristic shear strength - 0.6 x Rm: $\bar{x} = 645 \text{ daN}$

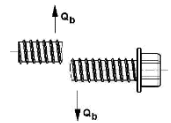

- Characteristic torque strength: $\bar{x} = 6.5 \text{ Nm}$

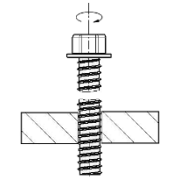

- Pull-out resistance (Pk) in accordance with the NF P 30-310 standard:

Thickness of the support Steel	Pk to daN
S235 - 4 mm	742
S235 - 6 mm	1186*
S235 - 8 mm	1186*
S235 - 10 mm	1186*
S235 - 12 mm	1186*

The values indicated do not include safety factors
*Fastener breakage

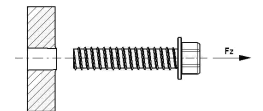

DIMENSIONS & CODES

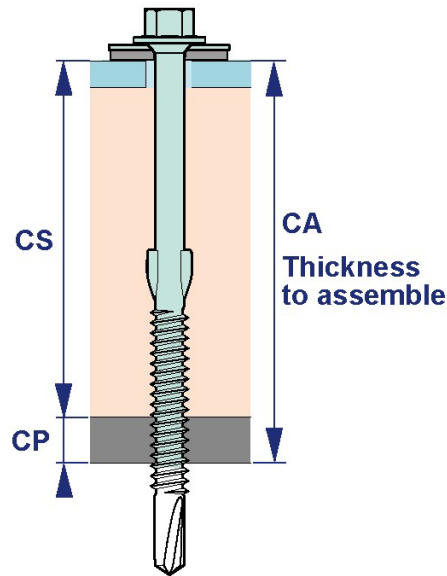

Ø x L (mm)	CP (mm)	CS mini (mm)	CA maxi (mm)	Hex Head	VULCA washer	Cond.	Code Natural
6.3 x 120	4 to 12	57	78	8	Ø 30	100	339 695

Ø : Nominal diameter - L : Length - CS_{mini} : Minimum clamping capacity - CA_{maxi} : Maximum assembly capacity - CP : Drilling capacity - Cond. : Packaging

CONFORMITY

- Complies with the CSTB 3297 V2 specification: Fibre-cement roofs for channel tiles under Technical Application Document.
- The characteristic resistances are the result of tests carried out by the LR ETANCO laboratory.
- Reaction to fire: A1 according to NF EN 13501-1 (only for the screw).

MARKING & LABELLING

- On packaging, natural screw: CANAL-DRILLNOX 12 TH8 A4 - Ø 6.3 x L + VI30 + CODE.

QUALITY CONTROL

- ISO 9001 certified quality management system according to certificate in force.

NOTE

These products are intended for professional installers landlords whose the related service includes supply and installation. In accordance with rules and normative regulation, it's their responsibility to check that the use of these products is in conformity to themselves needs and their customers. They have to insure as well the adequacy of this material with their real operating conditions. The company excludes any guarantee for the use that does not respect these conditions. His responsibility is limited to the strict compliance with the specifications stipulated on the customer's purchase order. The guarantee is limited to the replacement of defective parts acknowledged by the Company's technical service, without workforce costs and travel expenses. It excludes material damage or physical injury and others direct or indirect damages, material or immaterial, which may result from defective parts including installation that not complying with the use for which they are designed and produced.

Registration date: 18/03/2025 - Revision C

LR ETANCO is a member of:



LR ETANCO - Parc les Érables - Bât. 1 - 66 Route de Sartrouville
78231 Le Pecq Cedex France - www.etanco.eu
Tel: 01 34 80 52 00 - commercial.france@etanco.fr