

Manufacturer: ETANCO (FRANCE)

Parc les Erables – Bât 1 – 66 route de Sartrouville – BP 49 – 78231 LE PECQ Cedex
Tel.: +33 (0)1 34 80 52 00 – Fax: +33 (0)1 30 71 01 89

Product name:

DRILLNOX STAR BOIS TB13 A2 (304) Ø 4.9 x 35

Application:

Fastening skin panel onto timber rail

Description:

Self-drilling screw Ø 4.9 mm bi-metal
Aesthetic pan head Ø 13 mm, « STAR 25 » pattern,
natural or painted with baked EPOXY paint.
Pitch of 1.6 mm.
Drill point and firsts threads: Cemented steel.
Can be assembled with stainless steel Ø 10 mm.

Drilling capacity (CP):

1 to 3 x 0.75 mm steel sheet on wood.

Material:

Body: Austenitic stainless steel A2 Aisi 304 - 1.4301 - X5CrNi18-10
Drill point: Cemented steel
Washer: Stainless steel A2 + vulcanized EPDM , 2 mm, 70 Shore A

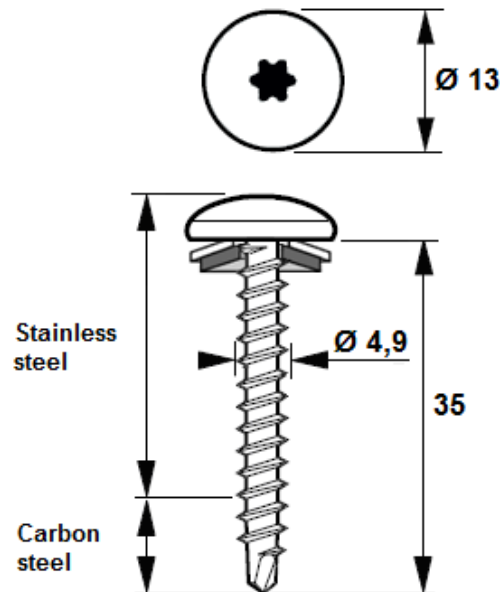

Material, coating and test of corrosion resistance:

- A2: Austenitic stainless steel A2 AISI 304

The corrosion resistance is define by Kesternich test (sulfur dioxide corrosion with general dampness condensation) according to NF EN 3231 (2 l)

Resisted more than 30 cycles before the appearance of red rust

Salt spray test according to NF ISO 9227 (March 2007):

No trace of red rust after 1000 hours

Drill point with coating:

No trace of red rust after 200 hours on drill point and firsts threads

Painting of heads and washers:

Powder painted without TGIC – without Gloss polyester Epoxy

The following tests were carried out on 1 mm zinc plated steel test panels and a nominal coating thickness of 60 µm.

Test	ISO / ASTM Requirement
Cross adhesion	ISO 2409 - class 0
Impact resistance	ASTM D 2794 - pass 20 inch/lbs
Flexibility	ISO 1519 - pass 4 mm
Cupping test	ISO 1520 - pass 6 mm
Scratch resistance	N / A
Hot salt spray resistance	ISO 9227 - pass 1,000 hours
Humidity resistance	ISO 6270 - pass 1,000 hours
Kesternich resistance	ISO 3231 - pass 25 cycles
Chemical resistance	Resistance to most acids, alkalis and oils at normal temperatures Can be affected by chlorinated solvents

Drilling time performance:

Conditions: a) Test material: Structural steel S355JR
 b) Tool used: Drilling test with FEIN SCS 6.3-19 X power 400 W mini with torque limiter and depth control

Drilling test	Unit	Ø 4,8	Ø 5,5	Ø 6,3 & 6,5
Drilling time	s/mm	< 2	< 2	< 2
Speed rotate	rpm	2000 *	2000 *	2000 *
Axial load	daN	16	20	27

* Real capacity of 1800 revolutions per minute

Drilling capacity, diameter, length (in mm) and packaging:

Drilling capacity CP	Ø x Length	CS minimum build up	Aesthetic pan head TB	Packaging
1 à 3 x 0.75	4.9 x 35	2.25	Ø 13	100
1 à 3 x 0.75	4.9 x 35 + VI 10	2.25	Ø 13	100

Tensile steel failure (Value in daN):

$\bar{x} = 570 \text{ daN}$

Characteristic resistance

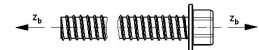

Shear steel failure – 0.6 x Rm (Value in daN):

$\bar{x} = 342 \text{ daN}$

Characteristic resistance

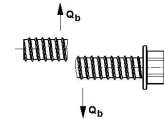

Torque steel failure (Value in daN):

$\bar{x} = 6.5 \text{ Nm}$

Characteristic resistance

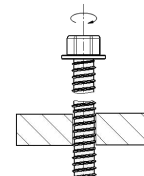

Pull-out failure – Top steel (Pk in daN) – According to NF P 30-314:

Characteristic resistance

Top steel S320	Wood (fir) 450 Kg/m3 Total Embedment depth
Screw Length	35 mm
0,75	243 daN
2 x 0,75	243 daN
3 x 0,75	243 daN

The indicated values do not include safety factors

Pull-out failure in wood (Pk in daN) – According to NF P 30-310:

Characteristic resistance

Wood (fir) 450 Kg/m3 Total Embedment depth
Screw length : 35 mm
243 daN
The indicated values do not include safety factors

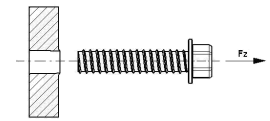

Shear failure of the assembly (Pk in daN) – According to NF P 30-316:

Characteristic resistance

Thickness in mm		daN
Top steel S320	Wood (fir) 450 Kg/m3	
0.75	Total Embedment depth	-
2 x 0.75	Total Embedment depth	-
3 x 0.75	Total Embedment depth	-
The indicated values do not include safety factors		

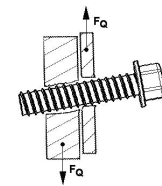

According to French standard:

Professional cladding rule

Recommended tool:

Screwdriver FEIN SCS 6,3 -19X power consumption 400 W mini with torque limiter (depth stop) and depth gauge
Drive bit : STAR 25

Labelling:

DRILLNOX STAR WOOD TB13 / A2 - Ø 4.9 x 35 + code
DRILLNOX STAR WOOD TB13 / A2 - Ø 4.9 x 35 + VI 10 + code

Quality control:

ISO 9001 : 2015

These products are intended for professional installers landlords whose the related service includes supply and installation. In accordance with rules and normative regulation, it's their responsibility to check that the use of these products is in conformity to themselves needs and their customers. They have to insure as well the adequacy of this material with their real operating conditions. The company excludes any guarantee for the use that does not respect these conditions. His responsibility is limited to the strict compliance with the specifications stipulated on the customer's purchase order. The guarantee is limited to the replacement of defective parts acknowledged by the Company's technical service, without workforce costs and travel expenses. It excludes material damage or physical injury and others direct or indirect damages, material or immaterial, which may result from defective parts including installation that not complying with the use for which they are designed and produced.