

Manufacturer: LR ETANCO (FRANCE)

Parc les Erables – Bât 1 – 66 route de Sartrouville – BP 49 – 78231 LE PECQ Cedex

Tel. : +33 (0)1 34 80 52 00 – Fax : +33 (0)1 30 71 01 89

Product name:

GOLDINOX BOIS TH8 A4 (316L) Ø 6.3 x 60

Application:

Steel sheet on fir wood.

Description:

Self-drilling bi-metal screw Ø 6.3

Hexagonal head of 8 mm. Natural finish or EPOXY powder painted stove hardened with flange Ø15 / 1.5 mm thickness

Pitch = 1,81 mm.

Drilling capacity (CP):

Sheet of steel from 0.75 to 3 x 0,75 mm on fir wood

Material:

Screw body: Austenitic stainless steel A4 AISI 316L - 1.4404 - X2CrNiMo17-12-2

Drill point and first threads: Cemented steel

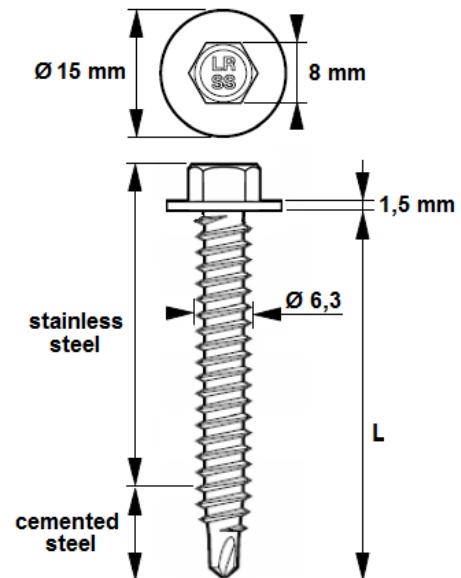

Not contractual position marking

Material, coating and test of corrosion resistance:

- A4: Austenitic stainless steel A4 AISI 316 L

Corrosion resistance level determined by Kesternich test (sulphur dioxide corrosion with general dampness condensation) according to NF EN 3231 (2 l):

Resisted to more than 30 cycles before the appearance of red rust

Salt spray test according to NF ISO 9227 (March 2007):

No trace of red rust after 1000 hours.

Surface-coated steel drill tip:

Resistance to corrosion of drill tip and steel-coated first threads: 200 hours SSTR (Salt Spray Resistance Test).

Drilling time Performance:

- Conditions: a) Test material : Structural steel S355 JR
 b) Tools used : Drilling test with SCS Fein 6.3-19X power 400 W mini with torque limiter and depth control

Drilling test	Unit	Ø 4.8	Ø 5.5	Ø 6.3 & 6.5
Drilling time	s/mm	< 2	< 2	< 2
Speed rotate	rpm	2000 *	2000 *	2000 *
Axial load	daN	16	20	27

* Under load: 1800 rotations/min

Drilling Capacity, diameter, length (in mm) and packaging:

Drilling capacity	Ø x Length	CS Capacity of maxi tightening	Hex head TH	Packaging
1 à 3 x 0.75	6.3 x 60	5	8	100

Tensile test (value in daN):

$\bar{x} = 1076 \text{ daN}$



Shear test value – 0.6 x Rm (value in daN):

$\bar{x} = 645 \text{ daN}$

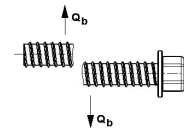

Breaking torque (in Nm):

$\bar{x} = 14 \text{ Nm}$

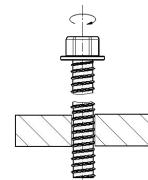

Pull out test values (Pk in daN) of top sheet - According to NF P 30-314

Superior steel sheet (S320)	Support fir wood 450 Kg/m3 Total anchoring
0,75	431 daN
2 x 0,75	439 daN
3 x 0,75	439 daN
Important: these values do not include safety coefficients and are provided for information purposes only.	

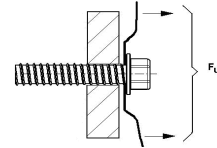

Pull out test values (Pk in daN) – According to NF P 30-310

Support fir wood 450 Kg/m3 Total anchoring
489 daN
Important: these values do not include safety coefficients and are provided for information purposes only.

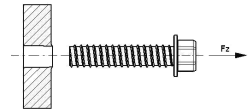

Shear load test values (Pk in daN) – According to NF P 30-316

Thickness of sheet steel (mm)		
Superior steel sheet (S320)	Support fir wood 450 Kg/m3 Total anchoring	daN
0.75	Total anchoring	-
2 x 0.75	Total anchoring	-
3 x 0.75	Total anchoring	-
Important: these values do not include safety coefficients and are provided for information purposes only.		

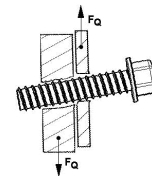

Conformity:

DTU 43.3 based on NF P 84-206
French professional regulations related to cladding

Recommended setting tools:

Screwing toll FEIN SCS 6.3 -19X power 400 W mini with torque limiter and depth control
Screw Tip : socket with 8 mm imprint hex head hollow

Marking - Labelling:

GOLDINOX BOIS TH8 / A4 - Ø 6.3 x 60 + CODE

Quality control:

ISO 9001 : 2015